

# MAIN STREET REVITALIZATION PLAN

Bridgeport, California



## Supplemental Design Guidelines

July 2013



Prepared by:

Opticos Design, Inc.

2100 Milvia St, Ste. 125  
Berkeley, CA 94704

p: 510.558.6957  
f: 510.898.0801

w: [opticosdesign.com](http://opticosdesign.com)

# Table of Contents

<b>Introduction</b>	<b>i</b>
Purpose and Intent	
Applicability	
<b>Private Realm</b>	<b>1-1</b>
Building Massing and Site Definition	
Building Frontage	
Building Facade Elements	
Pedestrian-Scaled Signage	
Suggested Materials and Color Palettes	
Building Frontage Improvements	
Example 1	
Example 2	
Example 3	
Example 4	
<b>Public Realm</b>	<b>2-1</b>
Streetscape Components	
Curb Extensions	
Signage and Wayfinding	
<b>Appendix: Gateway Design Elements</b>	<b>A-1</b>
Gateway Signage	
East Walker River Bridge	
Study 1	
Study 2	

## Purpose and Intent

This document provides a set of design guidelines for public and private projects in and around Main Street in Bridgeport. These guidelines provide a basic “road map” for Bridgeport’s ongoing revitalization and are supplemental to the 2013 Main Street Revitalization Plan.

For private property owners, the intent of this document is to establish a flexible palette of design techniques and approaches that can assist with building renovations and new construction projects and ensure a positive contribution to Bridgeport’s character. Private realm elements include the following:

- Building Massing and Site Definition;
- Building Frontage;
- Building Façade Elements; and
- Suggested Materials and Colors

For Mono County and other agencies involved with improvements to the public realm, this document provides a suggested palette of design elements that can improve the pedestrian experience along Main Street and build upon the community’s established character. Public realm elements include the following:

- Streetscape Elements;
- Curb Extensions and Strategies; and
- Signage and Wayfinding

Part of the community's character comes from the individuality present among properties. Buildings in Bridgeport follow a diverse range of styles, but two styles are most prevalent in the community:

- Colonial Revival / Early 20th Century: Buildings characterized by traditional compositions and massing, symmetrical and orderly composition of openings, and simple, traditional exterior details in wood, stone, and stucco
- Mid-Century Modern / Roadside : Buildings and elements characterized by horizontal proportions with vertical accents, streamlined exterior details, and playful signage and colors

Property owners and County staff should work together to maintain this architectural diversity among properties, in order to preserve Bridgeport’s unique identity. The suggested design guidelines that follow hope to balance this individuality with elements that can encourage and create a cohesive identity.

## Applicability

Design features described in this manual may require additional coordination and compliance with existing county and/or state regulations prior to implementation. Interested parties should always check with the appropriate agencies (such as Mono County Planning and/or Caltrans) for guidance regarding project permitting and approval.

# Building Massing and Site Definition

## Building Massing

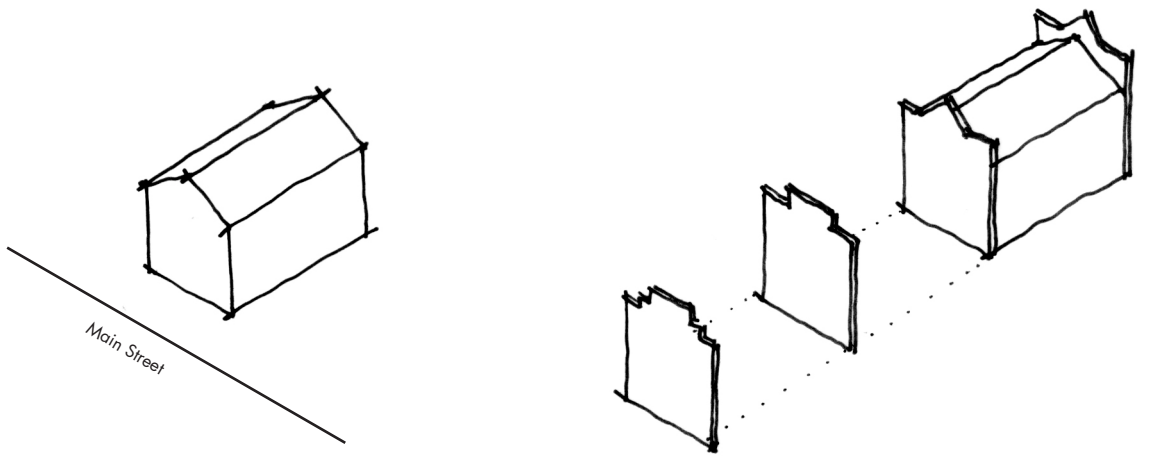

Building forms should be small-scaled, simple volumes.

End gables with false facades are very common in Bridgeport

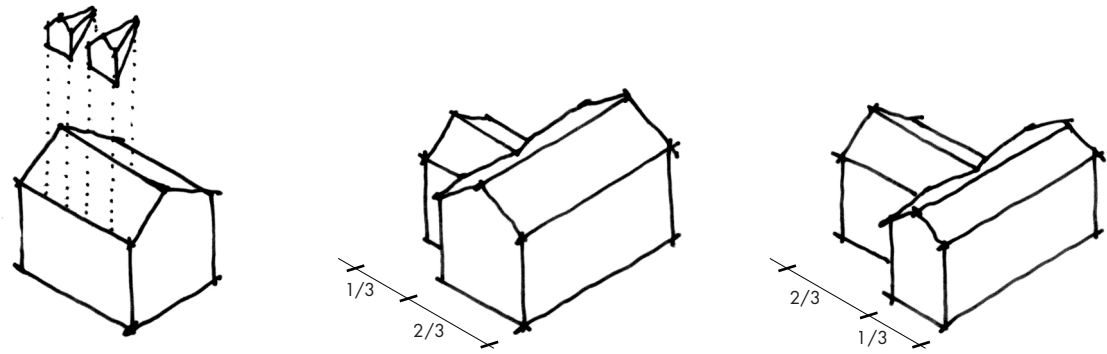

Side gable with optional dormers

Buildings can be a combination of rectilinear forms with gable-end or hipped roof.

## Facade Composition

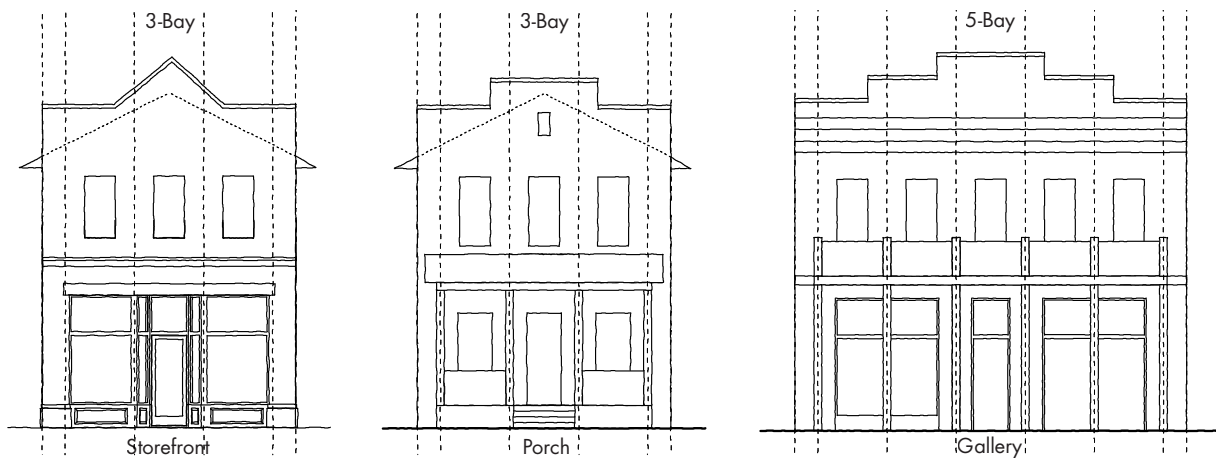

Facades are typically composed of multiple, regular bays; often the center is accentuated with an ornamental parapet. Other exterior elements and frontages work within the regularized bays: (left to right): a storefront, porch, and gallery.

## Site Definition

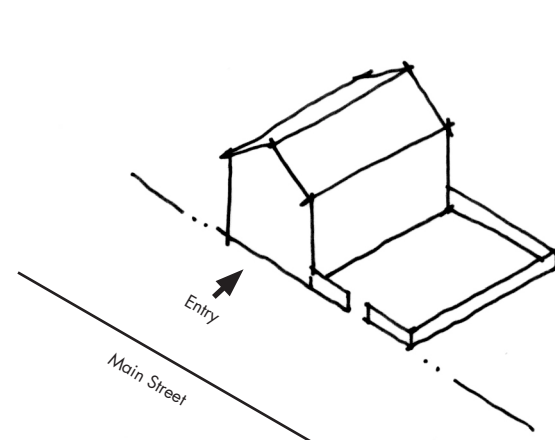

Building sits at the back of the sidewalk with a side yard; the side yard is defined with a fence, low masonry wall, or landscape.

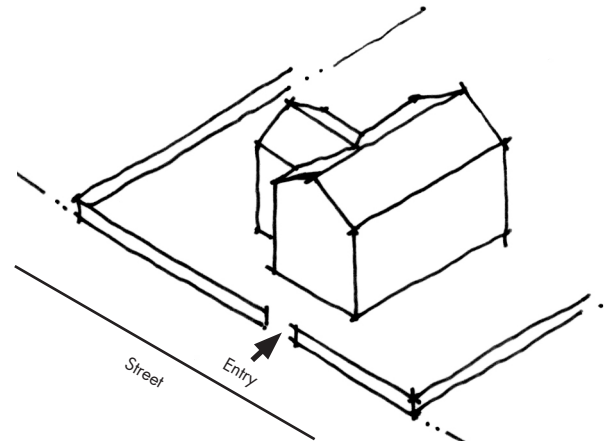

Building set back slightly from the lot line; public realm is defined by fence, landscape hedge, and/or low masonry wall.

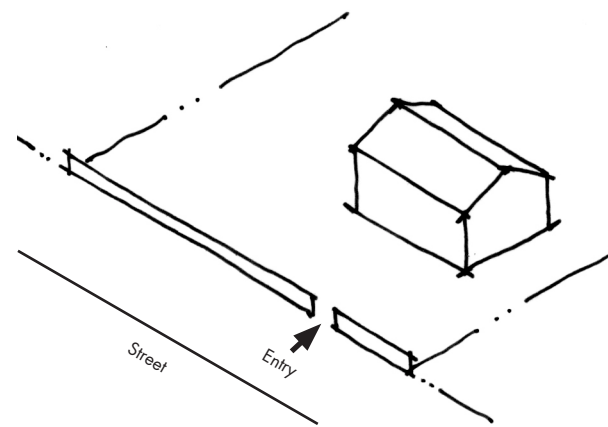

Building set back considerably from the lot line; a fence, landscape hedge, or low masonry wall creates a presence along the street.



Wood picket fence provides transparency



Wrought iron fence provides transparency



Wood fence is raised on a low masonry wall

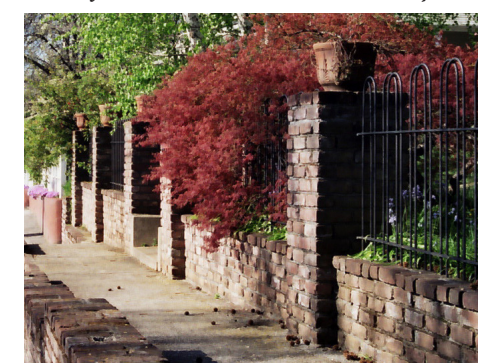

A low masonry wall can be used as a base to create a taller fence

## Fence/Hedge Examples

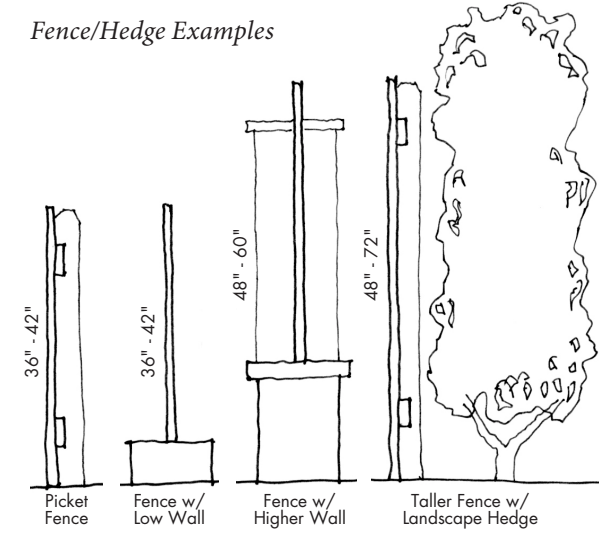

A hedge combined with a fence provides additional privacy and visual interest



This low wall helps define the street, while also providing a public bench and a private terrace for diners.

# Building Frontage Types

## 1. Stoop

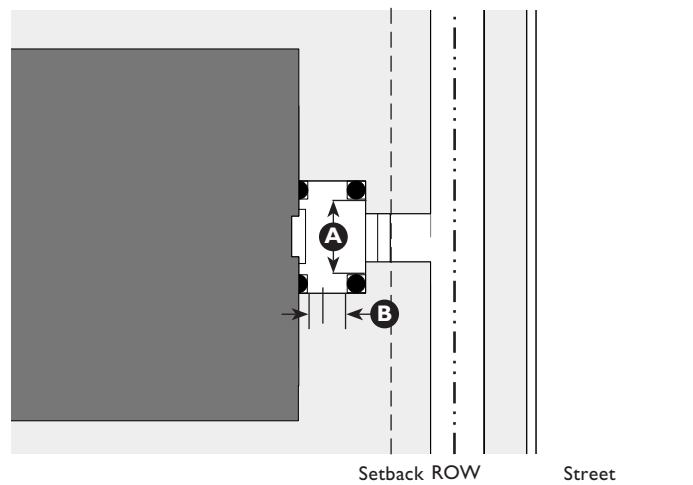
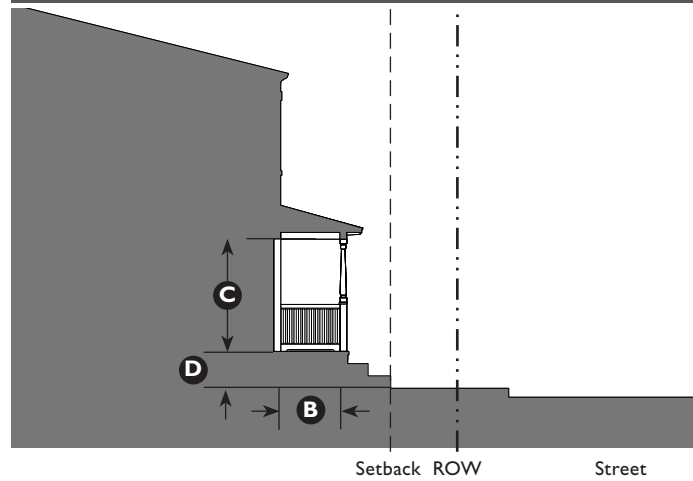

Stoop at the zero-lot line



Stoop



Stoop with deeper setback from the lot line

## 2. Porch

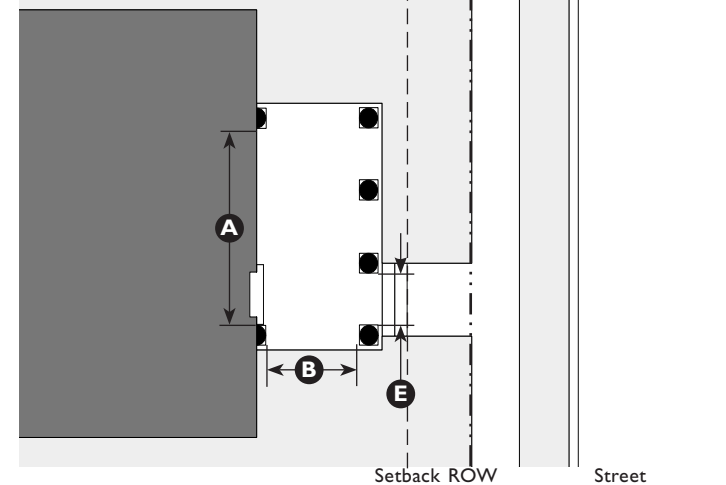
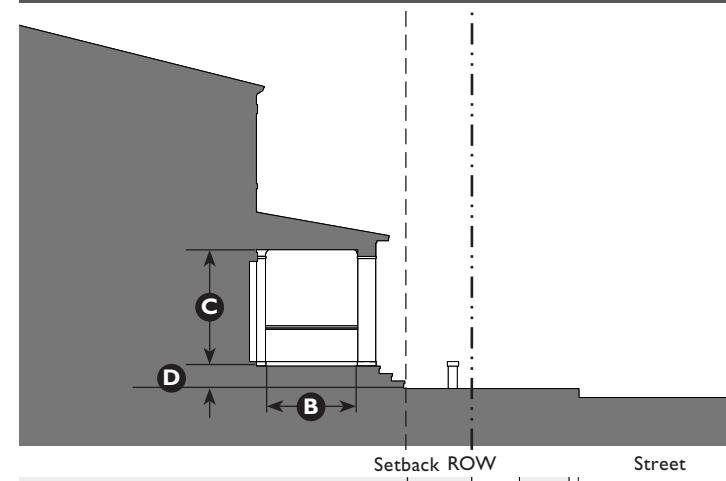

A porch on Main Street



Engaged porch at the Bridgeport Inn

**Key** --- ROW / Property Line    - - - - - Setback Line

### Description

**Stoop:** The main facade of the building is near the frontage line and the stoop should be elevated above the sidewalk to ensure privacy within the building. This type is appropriate for residential uses with small setbacks.

### Size

Width, Clear	5-8' typ.	<b>A</b>
Depth, Clear	5-8' typ.	<b>B</b>
Height, Clear	7-8' typ.	<b>C</b>
Height	1 story	
Finish Level above Sidewalk	12" min.	<b>D</b>

### Miscellaneous

Stairs may be perpendicular or parallel to the building facade.

Ramps should be parallel to facade or along the side of the building.

The entry door should be covered or recessed to provide shelter from the elements.

**Key** --- ROW / Property Line    - - - - - Setback Line

### Description

**Porch:** The main facade of the building is setback from sidewalk or road. The resulting front yard is typically very small and can be defined by a fence or hedge to spatially maintain the edge of the street.

### Size

Width, Clear	10' min. typ.	<b>A</b>
Depth, Clear	7' min. typ.	<b>B</b>
Height, Clear	7' min. typ.	<b>C</b>
Height	1-2 stories	
Finish Level above Sidewalk	12" typ.	<b>D</b>
Path of Travel	3' wide min.	<b>E</b>

### Miscellaneous

Porches are open on three sides and have a roof.

# Building Frontage Types (continued)

## 3. Shopfront

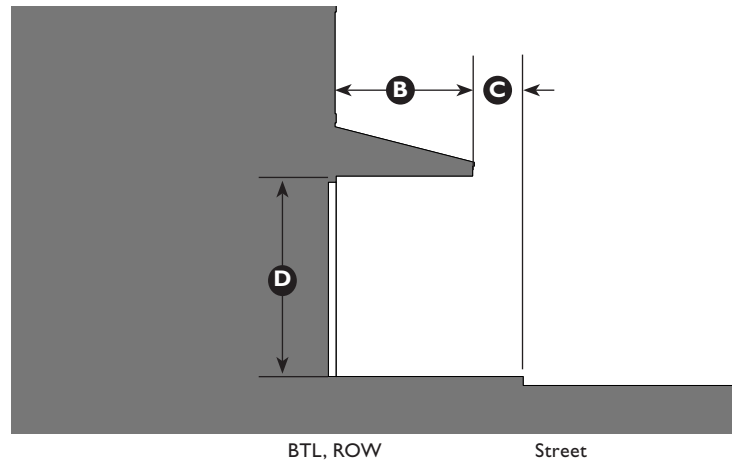

A storefront with a recessed entry



A storefront with an angled entry and divided lites



Storefront with a flush entrance and awning on Main Street

## 4. Gallery

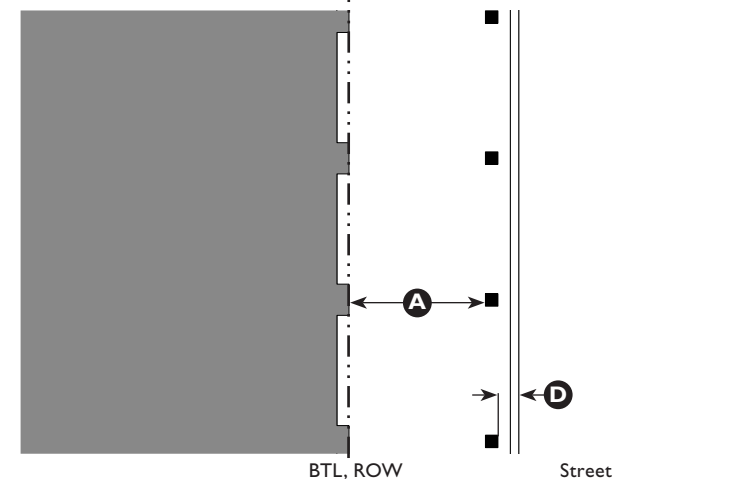
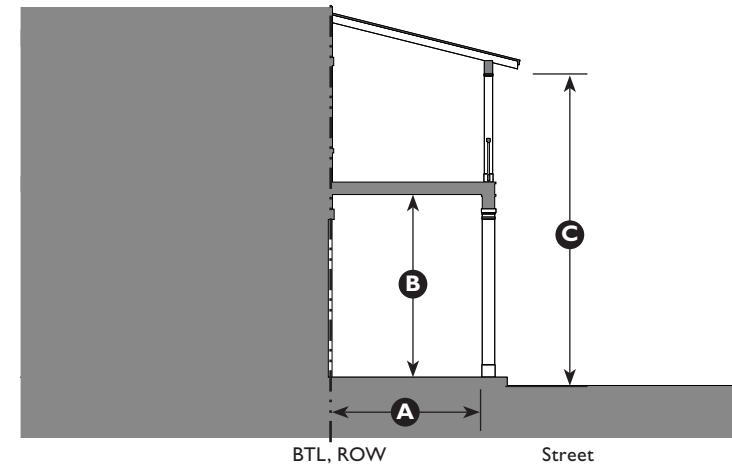

One-story gallery



One-story gallery



Two-story gallery

**Key** --- ROW / Property Line    - - - - - Setback Line

### Description

**Shopfront:** The main facade of the building is at or near the frontage line with an at-grade entrance along the public way. This type is intended for retail use. It has substantial glazing at the sidewalk level and may include an awning that may overlap the sidewalk. It may be used in conjunction with other frontage types.

### Size

Distance between Glazing	2' max. typ.	<b>(A)</b>
Ground Floor Transparency	50% min.	
<b>Awning</b>		
Depth	4' min. typ.	<b>(B)</b>
Setback from Curb	2' min.	<b>(C)</b>
Height, Clear	8' min.	<b>(D)</b>

### Miscellaneous

Residential windows shall not be used.  
Operable and open-ended awnings are encouraged.

**Key** --- ROW / Property Line    - - - - - Setback Line

### Description

**Gallery:** The gallery element overlaps the sidewalk. This type is intended for buildings with ground-floor commercial uses and may be one or two stories. The gallery should extend far enough from the building to provide adequate protection and circulation for pedestrians and extend close enough to the curb so that a pedestrian cannot bypass it.

### Size

Depth, Clear	8' min. typ.	<b>(A)</b>
Ground Floor Height, Clear	10' min.	<b>(B)</b>
Height	1-2 stories	<b>(C)</b>
Setback from Curb	2' min.; 3' max.	<b>(D)</b>

### Miscellaneous

Upper-story galleries facing the street must not be used to meet primary circulation requirements.  
Galleries should have a consistent depth along a frontage.  
Gallery must project over a sidewalk.

# Building Facade Elements

## Windows and Doors

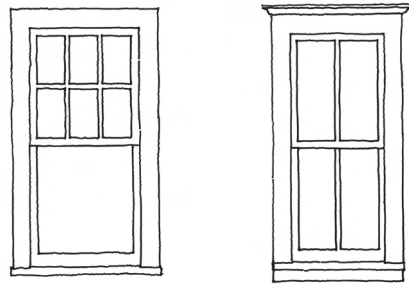

Vertically proportioned windows: 6-over-1 window pane; 2-over-2 window pane



Windows are multi-paned with true or simulated muntins

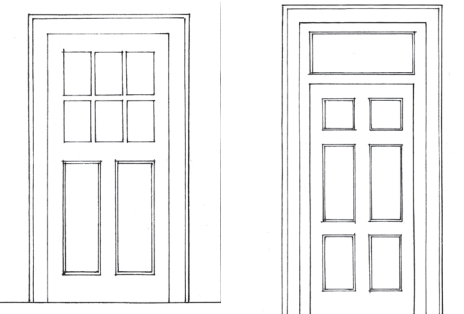

Doors with simple, rectilinear panels and windows

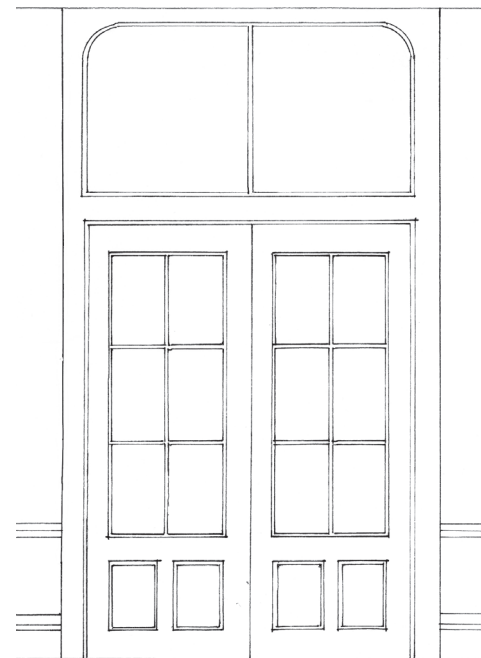

Storefront door with transom, panels and glazing

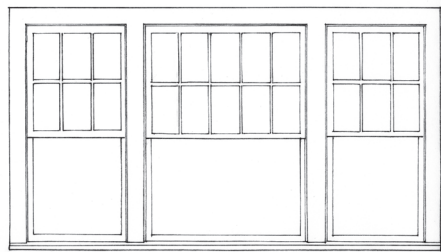

Vertically-proportioned ganged windows allow for a wider opening



Box window projects from the building



Storefront entry through paired doors

## Attached Elements

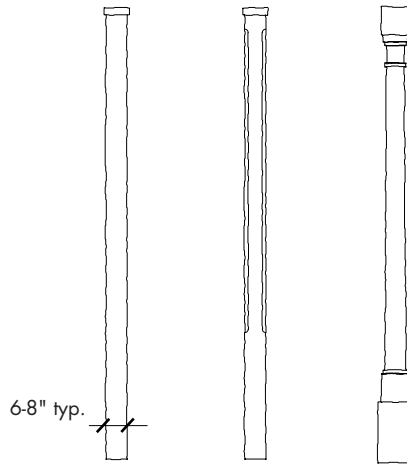

6-8" typ.

Columns: Simple, chamfered, with imposts



Balcony

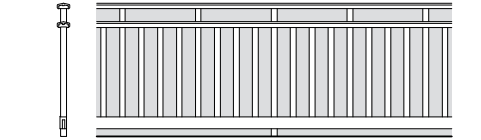
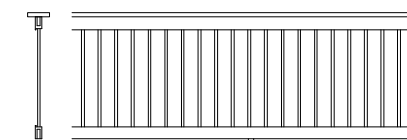
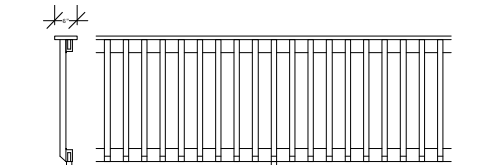
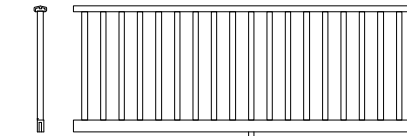

Details of railing types

## Simple Shopfront Renovations

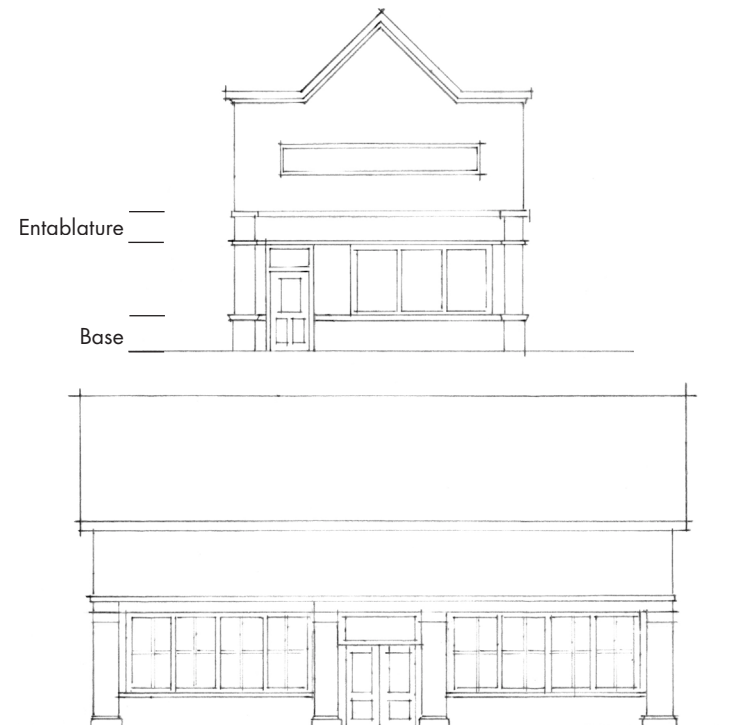
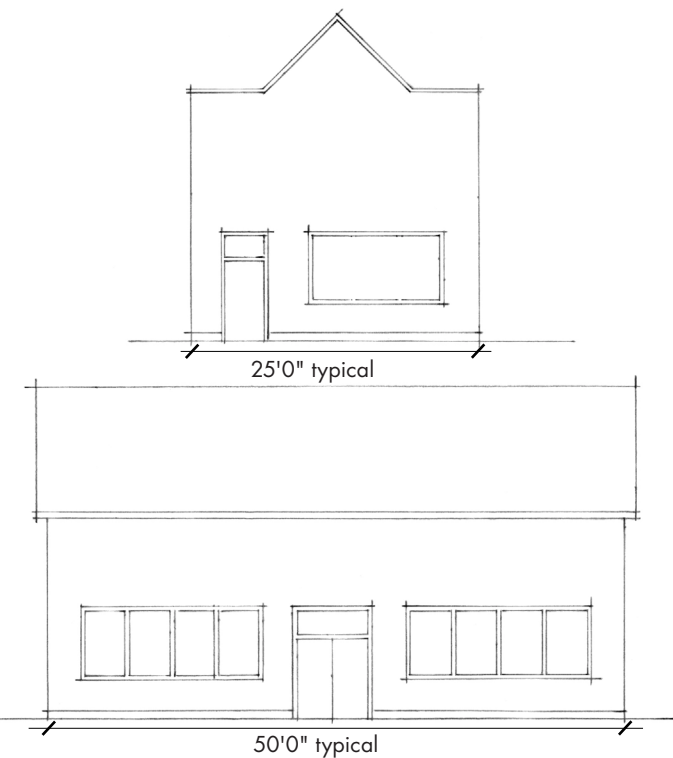

*Narrow example:* Character is improved by simply adding a base below the windows and an entablature above; two pilasters frame the corners; the windows are divided into three vertically-proportioned ganged windows.

*Wide example:* Character is enhanced by framing the ganged windows with pilasters supporting an entablature that runs the length of the storefront; the windows sit on a base and are articulated with muntins; the doors are paneled.

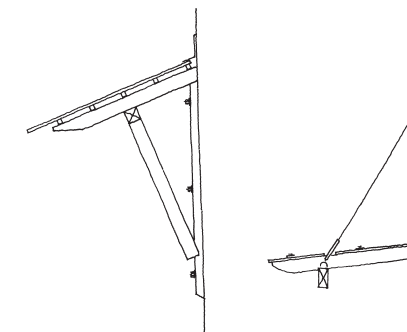

Awning details



Canvas awning; ideally retractable for more sunlight in the winter months.

# Pedestrian-Scaled Signage

## 1. Awning Signage



### A. Description

Awnings are a traditional shopfront fitting and can be used to protect merchants' wares and keep shopfront interiors shaded and cool in hot weather. Retail tenant signs may be painted, screen printed, or appliquéd on the awnings.

### B. Examples



## 2. Blade Signage

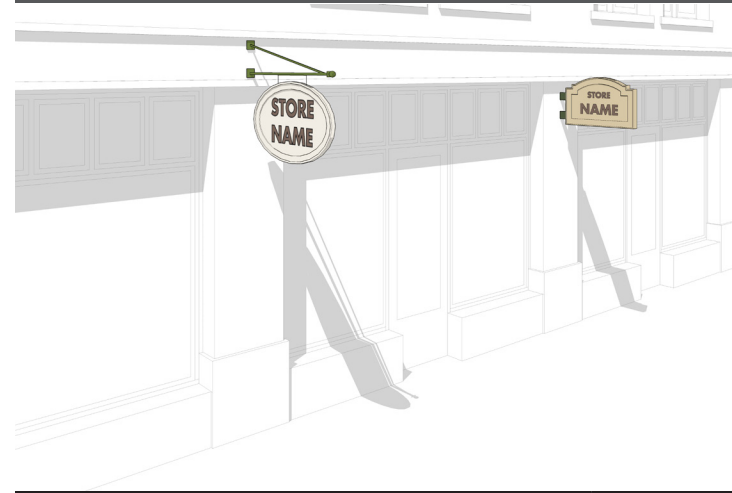

### A. Description

Blade signs mount perpendicular to a building's facade. They are typically hung from decorative cast or wrought iron brackets or from the underside of beams or ceilings of a gallery, arcade, or similar covered area. They are typically hung in a manner that permits them to swing slightly. These signs are small, pedestrian-scaled, and easily read from both sides. Often, a blade sign offers the opportunity for a more creative or "playful" sign. Blade signs shall be hung well out of reach of pedestrians and all exposed edges of the sign shall be finished.

### B. Examples



## 3. Wall Signage



### A. Description

Wall signs are flat against the facade consisting of a single panel with raised letters, individual cut letters applied directly to the building, or painted directly on the surface of the building. Wall signs are typically placed directly above the main entrance and often run horizontally along the "expression line" or entablature of traditional buildings. Wall signs do not protrude beyond the roof line or cornice of a building. Wall signs are typically intended to be seen from a distance and are often accompanied by additional pedestrian-scaled signage.

### B. Examples



## 4. Window Signage



### A. Description

Window signs are professionally painted, consisting of individual letters and designs or gold leaf individual letters and designs, and are applied directly to the inside of a window. Window signs offer a high level of craftsmanship and visibility, and are often used for small professional offices. Window signs are often repeated on storefronts with several divided openings; however, repetition should be done with great care to ensure that the entrance to the business is clearly distinguished.

### B. Examples



# Suggested Materials and Colors

Materials	
Cladding	Predominantly siding in wood, composition board, or fiber-cement board with horizontal shiplap, beaded lap, or beveled profile. Vertical board and batten siding may also be used in 12-16" widths. Vinyl and T-111 siding are strongly discouraged. Corrugated metal should be used sparingly.
Foundations	Brick, stone, cast stone, painted concrete, or stucco.
Roofing	Building and porch roofs may be a built-up membrane (flat roofs only) composition shingle, wood shake, slate, or corrugated or standing seam metal.
Windows	Wood, aluminum-clad wood, or vinyl. Glass should be clear and non-reflective.
Doors	Principal doors in wood, aluminum-clad wood, vinyl-clad wood, factory-painted aluminum, or fiberglass.
Storefronts	Wood, aluminum-clad wood, or metal frame with simulated or true divided lites. Glass should be clear and non-reflective.
Trim	Wood, composition board, fiber-cement board, and molded millwork for built-up sections. PVC trim is discouraged. For soffits and porch ceilings, GWB, plaster, T&G wood, exposed rafters, or composite. Continuous perforated soffit materials and the use of vinyl panel systems are strongly discouraged.
Gutters	Half round or ogee-profile metal. PVC is strongly discouraged.
Downspouts	Round or rectangular metal. PVC is strongly discouraged.
Columns	Wood, fiberglass, steel, or composite. Column bases may be brick or cast stone.
Railings	Milled-wood top and bottom rails with square balusters in wood, or wrought iron. PVC trim is discouraged.

Materials (continued)	
Chimneys	Common brick, stone, cast stone, stucco, or metal stovepipe.
Signage	Painted wood or metal are encouraged.
Colors	
Cladding	Siding is typically white, off-white, cream, grey-green, grey-blue, brick-red, light yellow, or natural wood. Brick may be red or additional natural colors.
Roofing	Standing seam metal roofs are typically natural, black, brown, red, or dark green finish. Roof shingles are typically natural wood, dark grey or black.
Windows	Sashes and frames are typically dark stained or painted white, off-white, cream, dark red, dark green, or dark blue. Shutters may be painted to match sash/frame color.
Trim	White or off-white.
Gutters/Downspouts	White, off-white, painted dark green or dark red.
Columns	White or off-white.
Railings	Wood railings dark stained or painted white or off-white. Wrought iron grilles and rails should be painted black.

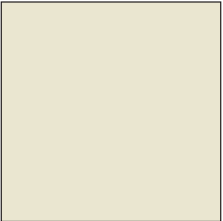
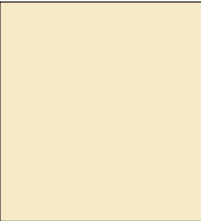
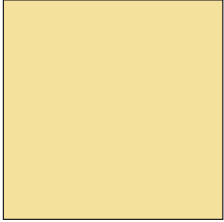
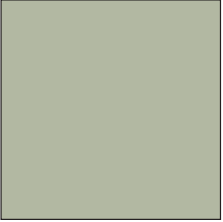

## Suggested Cladding Colors

		
<i>White (B. Moore CC869 or similar)</i>	<i>Off-white (B. Moore HC27 or similar)</i>	<i>Cream (B. Moore HC6 or similar)</i>
		
<i>Lt. yellow (B. Moore 290 or similar)</i>	<i>Grey-green (Moore HC114 or similar)</i>	<i>Brick-red (B. Moore HC50 or similar)</i>

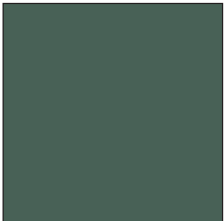
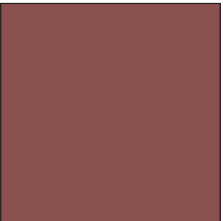
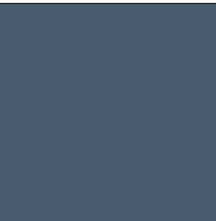
## Suggested Window Sash and Frame Colors

		
<i>Dk. green (B. Moore HC135 or similar)</i>	<i>Dark red (B. Moore 1295 or similar)</i>	<i>Dark blue (B. Moore HC156 or similar)</i>

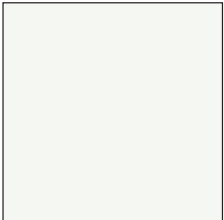
## Suggested Trim Colors

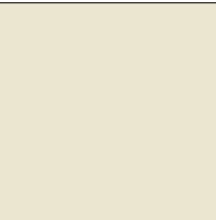
		
<i>White (B. Moore OC65 or similar)</i>	<i>White (B. Moore AC40 or similar)</i>	<i>Off-white (B. Moore HC27 or similar)</i>

## Suggested Wood Stains

		
<i>Spice Chest (S. Williams SW3513 or similar)</i>	<i>Mission Wall (S. Williams SW3502 or similar)</i>	<i>Yankee Bam (S. Williams SW3505 or similar)</i>

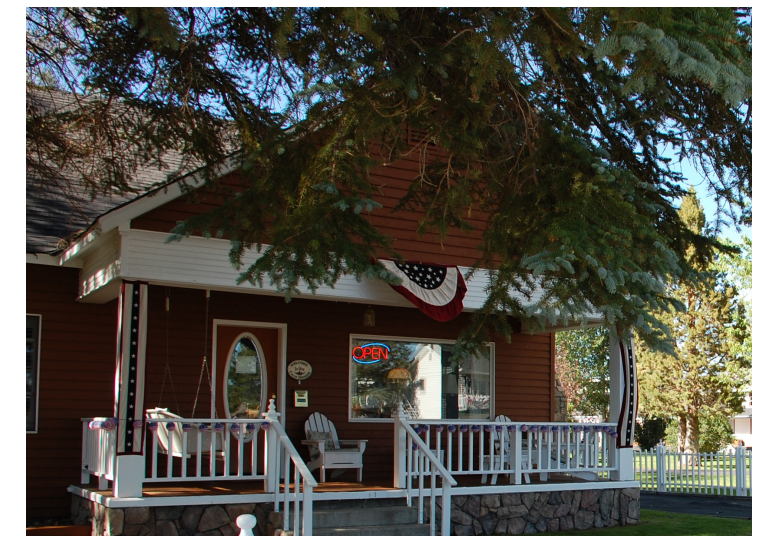



# Building Frontage Improvements: Example 1

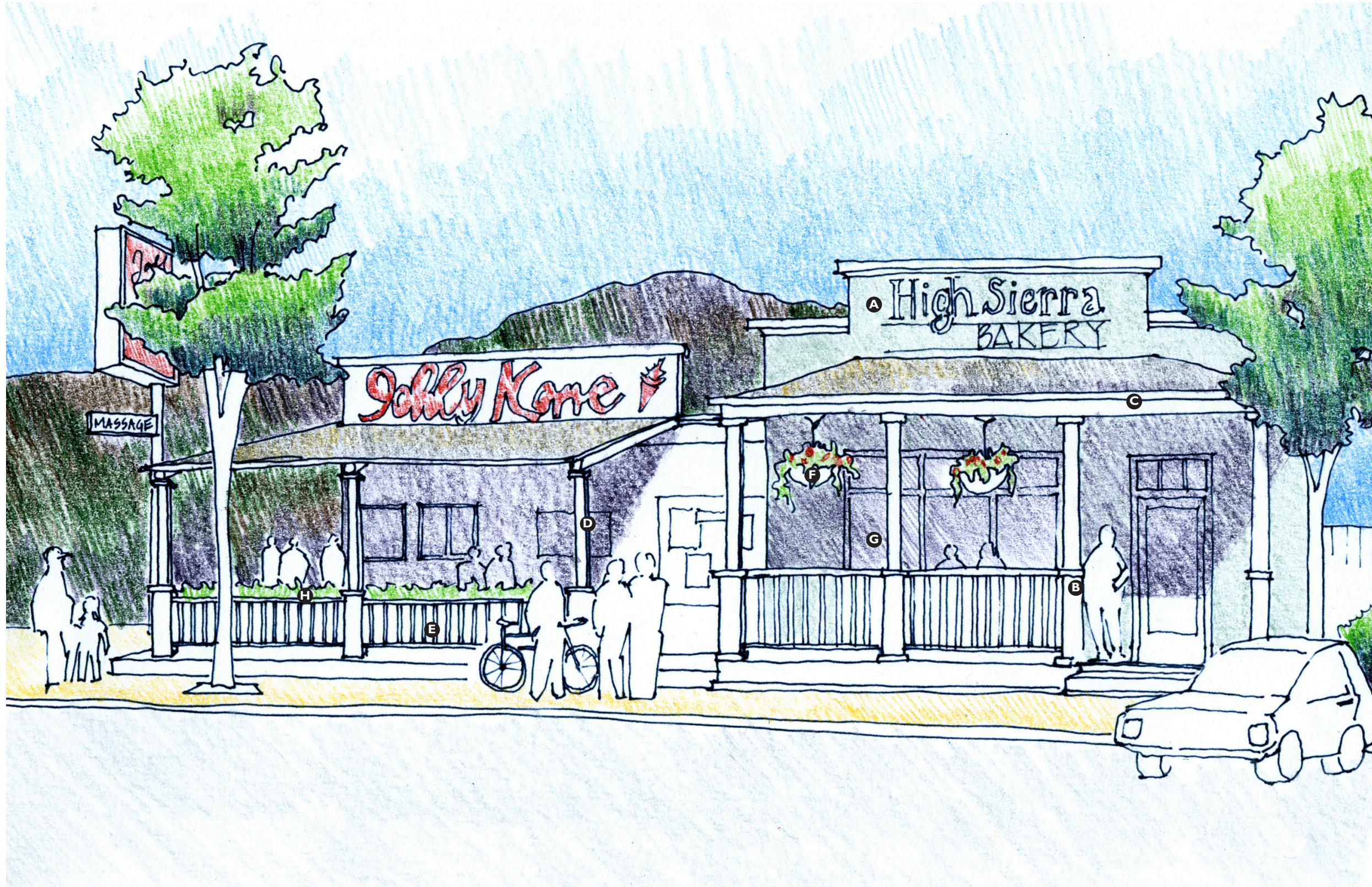

Example 1

- False storefronts with integral wall signage; painted or raised lettering **(A)**
- Porch frontage **(B)**
- 1'0" Simple entablature with half-round gutter **(C)**
- Square stock columns (6" min.) with articulated capitals and bases **(D)**
- Wood pickets painted (2") **(E)**
- Hanging planters **(F)**
- Large, articulated storefront window **(G)**
- Box planters **(H)**

# Building Frontage Improvements: Example 2



Example 2

- False storefront (A)
- Masonry base (Brick or stone) (B)
- Simple cornice (6-8" deep) (C)
- Ganged windows (D)
- Board and batten siding (E)
- Paneled door (F)
- Wood picket fence sits on a low masonry wall (G)
- Fence steps back from lot line, creating space for street furniture (H)
- Perpendicular blade sign (I)

# Building Frontage Improvements: Example 3

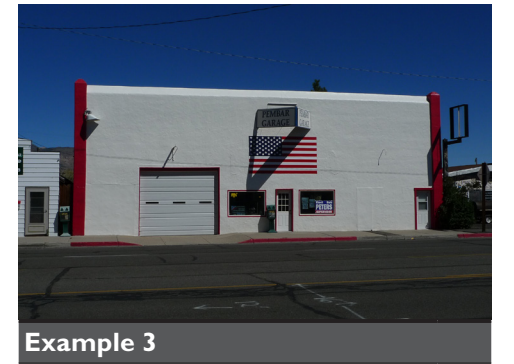
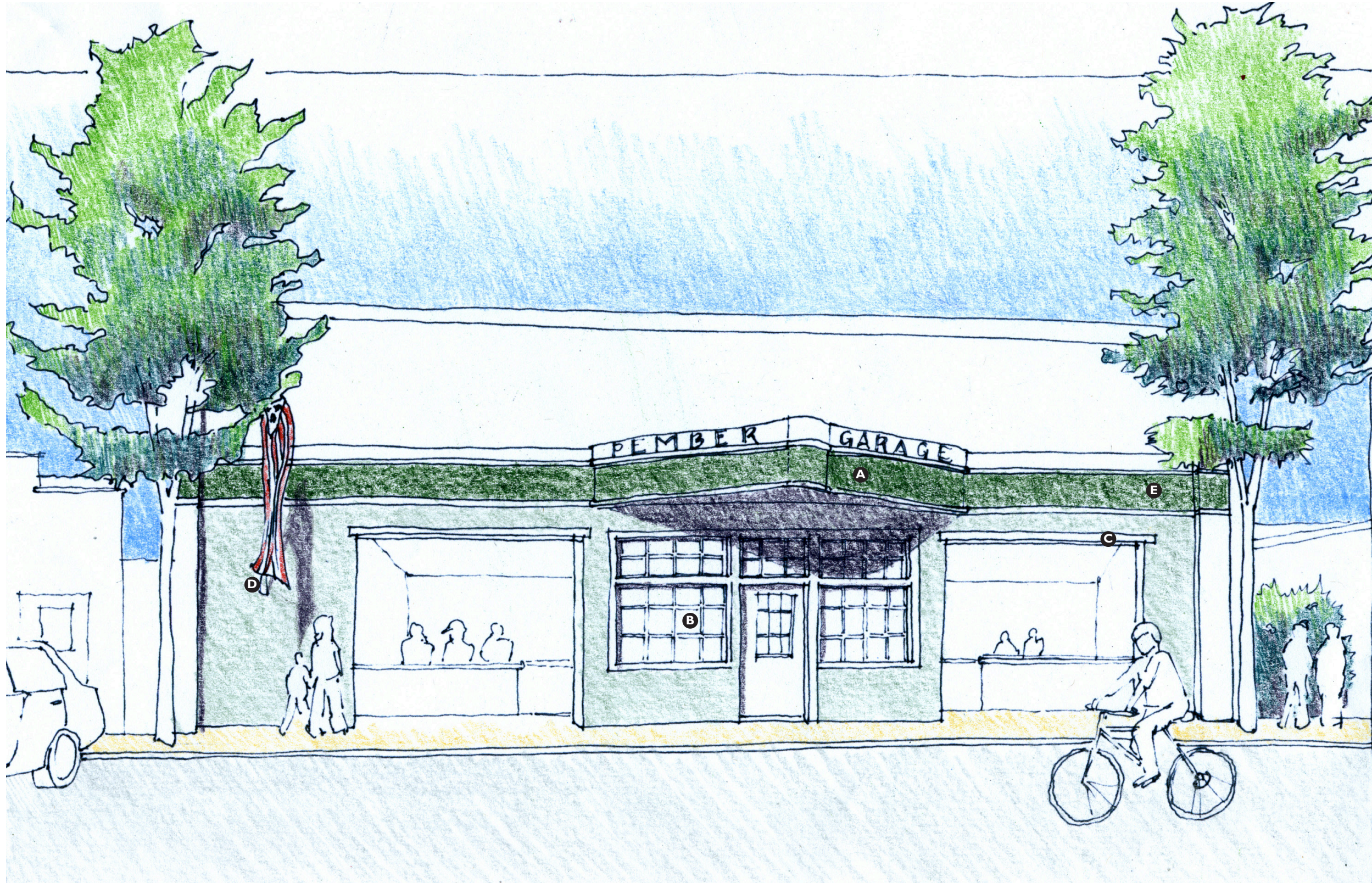

Example 3

- Lowered projecting awning A
- Glazing with divided lites B
- Roll-up garage doors engage the street C
- Projecting flagpole D
- Painted string course E

# Building Frontage Improvements: Example 4



**Example 4**

- Signage hangs from the existing station canopy **(A)**
- 3'6" Masonry wall built on the property line **(B)**
- Umbrellas add color and interest **(C)**
- Storefront frontage **(D)**
- Painted wood siding **(E)**
- Built-in planters in low-masonry wall **(F)**

# Streetscape Components

## Street Trees

Recommended Tree Species		
Species	Height	Spread
Western hackberry ( <i>Celtis reticulata</i> )	10-25 feet	10-25 feet
Quaking aspen ( <i>Populus tremuloides</i> )	40-50 feet	25 feet
Honey locust ( <i>Gleditsia triacanthos inermis</i> )	30-70 feet	35-50 feet
Common hackberry ( <i>Celtis occidentalis</i> )	40-70 feet	50 feet



**Honey Locust**  
 (Photos courtesy of: <http://gardens.missouri.edu/about/descriptions/treerails/TMaps/LowryMallPhotos/lowryweb/Gleditsia-triacanthos-sum-lg.jpg> and [http://www.meridian.k12.il.us/Middle%20School/student\\_work/katiepetrowsky/Honey\\_Locust.html](http://www.meridian.k12.il.us/Middle%20School/student_work/katiepetrowsky/Honey_Locust.html))

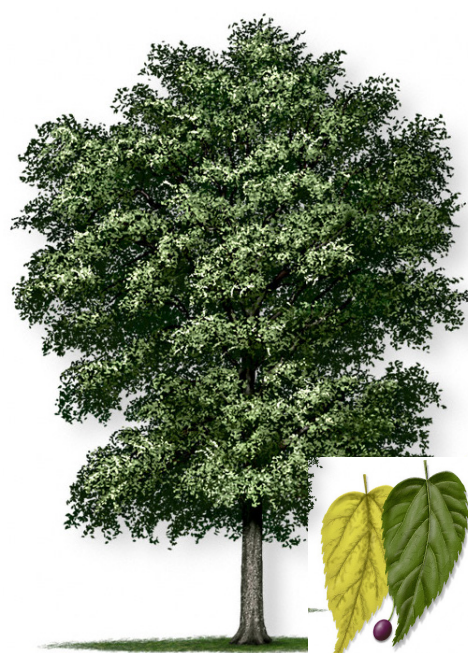

**Western Hackberry**  
 (Photo courtesy of: <http://texasreed.tamu.edu/images/Treelimages/hackberry150.jpg>)



Aspens as street trees in Crested Butte, CO

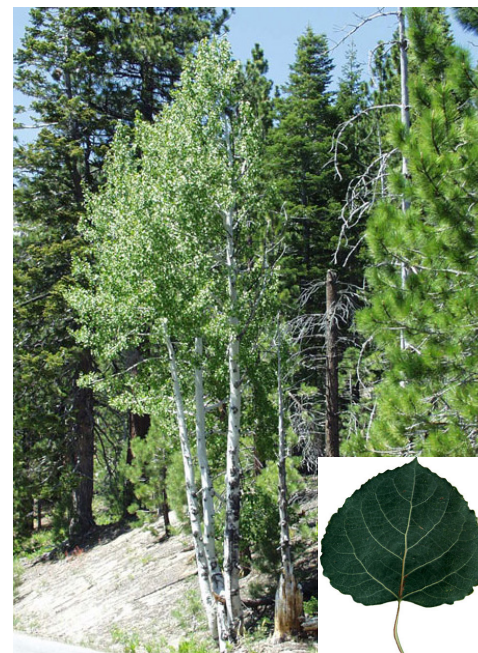

**Quaking Aspen**  
 (Photos courtesy of: <http://selectree.calpoly.edu/photos.lasso?rid=1137&-session=selectree:6CC697310c8d523948UiNV805992> and [http://www.meridian.k12.il.us/middle%20school/student\\_work/jennifer/Quaking%20Aspen.html](http://www.meridian.k12.il.us/middle%20school/student_work/jennifer/Quaking%20Aspen.html))

## Tree Grates

**R-8819**  
 Greenwich Collection Tree Grate  
 48" x 72"



**R-8808**  
 Parkway Collection Tree Grate  
 36" x 72"

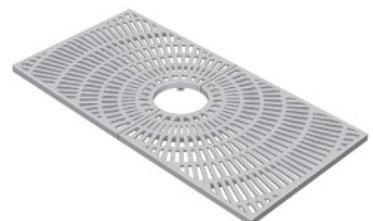

**R-8721-A**  
 Parkway Collection Tree Grate  
 48" x 48"



Neenah Foundry tree grates - Greenwich and Parkway Collections; the rectangular tree grates can be used along Main Street where the sidewalks are relatively narrow.

## Pedestrian-Scaled Lighting



Existing historic light fixture along Main St.

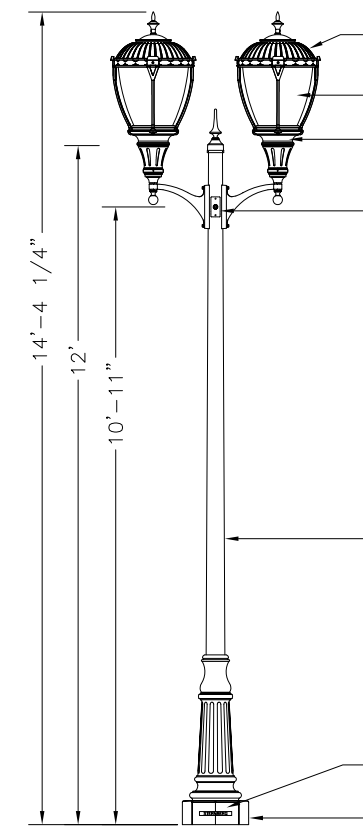

Sternberg light fixture specified for the School St. Plaza project.

Source: Sternberg Lighting

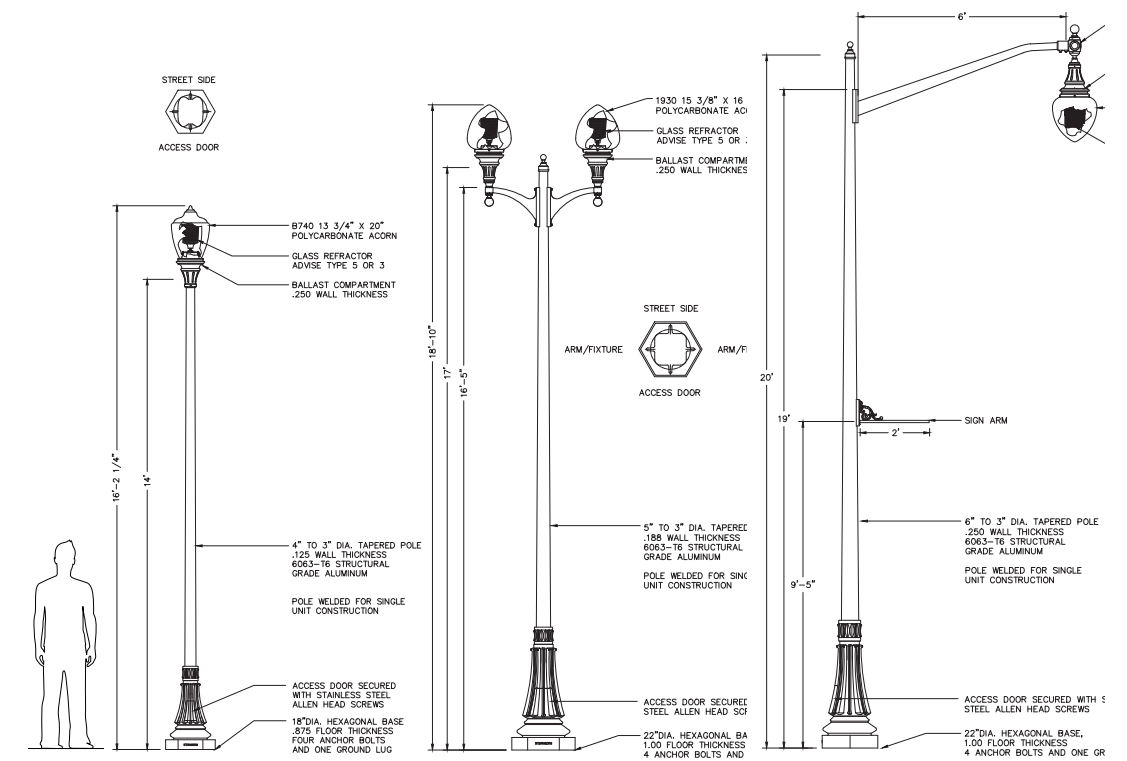

14' Pole with Acorn Fixture, similar to existing luminaires, for use along Main Street, 50' o.c. typ.

16.5' Pole with double Acorn fixture for use along Main Street, 100' o.c. typ.

20' Pole with drop acorn fixture for use along entry routes into Bridgeport, 100' - 200' o.c. typ.

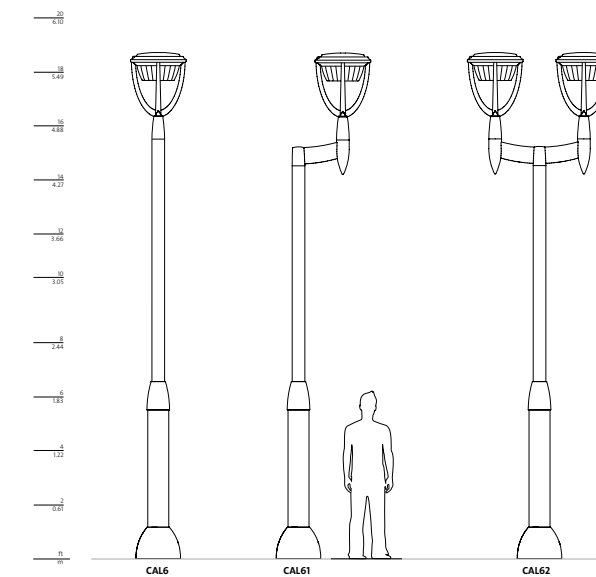

Source: Philips Lumec Lighting

Lighting Alternative: Philips Lumec Callisto lantern series. Pole height can be specified between 8-18 feet tall, at 6" increments.



# Streetscape Components (continued)

## Benches

### Traditional

### Contemporary

**Plainwell™ Specifications**

**Benches**

The Plainwell bench is available with seats constructed of aluminum or wood. The aluminum end frames on the wood bench and the all aluminum bench may be specified with Pangard II® powdercoat in standard colors; optional colors available for an upcharge. Available in two lengths, the 72" and 96" bench may both be specified with a center arm. The 96" bench may also be specified with 2 intermediate arms, placed at equal intervals. Freestanding/surface mount support is standard.

72" bench      72" bench with center arm      96" bench with center arm

**Finishes**

*Interior* woods are finished with Landscape Forms' exclusive LF-80 wood finish, a clear, catalyzed acrylic catalyzed acrylic lacquer.

*Exterior* woods are unfinished and will weather to a soft pewter gray, requiring no future maintenance.

*Metal* is finished with Landscape Forms' proprietary Pangard II® polyester powdercoat, a hard yet flexible finish that resists rusting, chipping, peeling and fading. Call for standard color chart. A wide array of optional colors may be specified for an upcharge.

**To Specify**

**Bench:** Select Plainwell bench, 72" or 96" length, wood type or aluminum seat and powdercoat color. Specify with or without center arm or intermediate arms for 96" bench.

**Litter Receptacle:** Select Plainwell litter, wood type or aluminum side panels, powdercoat color. Specify top or side opening; if side opening is specified, select with or without sand pan.

Visit [landscapeforms.com](http://landscapeforms.com); click Design Tools, Materials/Colors link for standard offerings, including FSC wood options.

**NOTES:**

- 1.) ALL STL. MEMBERS COATED W/ ZINC RICH EPOXY THEN FINISHED W/ POLYESTER POWDER COATING.
- 2.) 1/2" X 3 3/4" EXPANSION ANCHOR BOLTS PROVIDED.
- 3.) CUSTOM LETTERING AVAILABLE FOR RECESSED SIDE PANELS (TOTAL OF 37 SPACES)

**LENGTH OPTIONS:**

- 6" BENCH
- 8" BENCH

**DuMor, inc.**  
P.O. Box 142 Milltown, PA 17059-0142

SCALE: NONE TITLE: BENCH  
DATE DRAWN: 3/22/14 REV: D  
DRAWN BY: JAM REV: 11/22/09  
REV: 07/14

1 of 2

### Traditional

### Contemporary

**Litter Receptacles**

The Plainwell litter receptacle has a 35-gallon capacity, and includes a black polyethylene liner. Side panels are available in aluminum or a selection of woods. Metal parts finished with Pangard II® powdercoat available in standard colors; optional colors available for an upcharge. Frame and aluminum side panel may be specified in different colors. Rotomolded black polyethylene top is attached by cable to the receptacle. Lid available in top opening or side opening styles. Freestanding/surface mount support is standard. Optional sand pan available for side opening receptacles. Unit is emptied by lifting bag from top.

**Specifications - 2 3/8" schedule 40 steel pipe, 9 gauge**

Model #	# Bikes	Type of mount	weight	length	width	height	Space Requirement
2114	2	below grade	40 lbs.	30"	2.4"	32"	68" x 110"
2115	2	flange mount	39 lbs.	34"	6"	32"	68" x 110"

**Specifications - 2" X 2" X 3/16" square tubing, 7 gauge**

Model #	# Bikes	Type of mount	weight	length	width	height	Space Requirement
2214	2	below grade	47 lbs.	30"	2.4"	32"	68" x 110"
2215	2	flange mount	43 lbs.	34"	6"	32"	68" x 110"

**To Specify**

**Bicilinea:** Specify collection and product name.

**Bola and Ring:** Select bike rack style. Specify powdercoat color or stainless steel.

**Flo:** Select surface mount or embedded style. Specify powdercoat color or stainless steel.

**Key:** Specify grey or red.

**Pi and Ride:** Select surface mount or embedded style. Specify powdercoat color.



DuMor 58 series bench



Landscape Forms Plainwell bench



DuMor 102-22-FTO trash receptacle



Landscape Forms Plainwell trash receptacle

## Trash Receptacles

### Traditional

### Contemporary

**Litter Receptacles**

The Plainwell litter receptacle has a 35-gallon capacity, and includes a black polyethylene liner. Side panels are available in aluminum or a selection of woods. Metal parts finished with Pangard II® powdercoat available in standard colors; optional colors available for an upcharge. Frame and aluminum side panel may be specified in different colors. Rotomolded black polyethylene top is attached by cable to the receptacle. Lid available in top opening or side opening styles. Freestanding/surface mount support is standard. Optional sand pan available for side opening receptacles. Unit is emptied by lifting bag from top.

**Specifications - 2 3/8" schedule 40 steel pipe, 9 gauge**

Model #	# Bikes	Type of mount	weight	length	width	height	Space Requirement
2114	2	below grade	40 lbs.	30"	2.4"	32"	68" x 110"
2115	2	flange mount	39 lbs.	34"	6"	32"	68" x 110"

**Specifications - 2" X 2" X 3/16" square tubing, 7 gauge**

Model #	# Bikes	Type of mount	weight	length	width	height	Space Requirement
2214	2	below grade	47 lbs.	30"	2.4"	32"	68" x 110"
2215	2	flange mount	43 lbs.	34"	6"	32"	68" x 110"

**To Specify**

**Bicilinea:** Specify collection and product name.

**Bola and Ring:** Select bike rack style. Specify powdercoat color or stainless steel.

**Flo:** Select surface mount or embedded style. Specify powdercoat color or stainless steel.

**Key:** Specify grey or red.

**Pi and Ride:** Select surface mount or embedded style. Specify powdercoat color.

### Traditional

### Contemporary

**Litter Receptacles**

The Plainwell litter receptacle has a 35-gallon capacity, and includes a black polyethylene liner. Side panels are available in aluminum or a selection of woods. Metal parts finished with Pangard II® powdercoat available in standard colors; optional colors available for an upcharge. Frame and aluminum side panel may be specified in different colors. Rotomolded black polyethylene top is attached by cable to the receptacle. Lid available in top opening or side opening styles. Freestanding/surface mount support is standard. Optional sand pan available for side opening receptacles. Unit is emptied by lifting bag from top.

**Specifications - 2 3/8" schedule 40 steel pipe, 9 gauge**

Model #	# Bikes	Type of mount	weight	length	width	height	Space Requirement
2114	2	below grade	40 lbs.	30"	2.4"	32"	68" x 110"
2115	2	flange mount	39 lbs.	34"	6"	32"	68" x 110"

**Specifications - 2" X 2" X 3/16" square tubing, 7 gauge**

Model #	# Bikes	Type of mount	weight	length	width	height	Space Requirement
2214	2	below grade	47 lbs.	30"	2.4"	32"	68" x 110"
2215	2	flange mount	43 lbs.	34"	6"	32"	68" x 110"

**To Specify**

**Bicilinea:** Specify collection and product name.

**Bola and Ring:** Select bike rack style. Specify powdercoat color or stainless steel.

**Flo:** Select surface mount or embedded style. Specify powdercoat color or stainless steel.

**Key:** Specify grey or red.

**Pi and Ride:** Select surface mount or embedded style. Specify powdercoat color.



DuMor 102-22-FTO trash receptacle



Landscape Forms Plainwell trash receptacle

## Bicycle Racks

### Traditional

### Contemporary

**Saris Branded Bike Dock; place along the sidewalk every 10+ feet to park 2 bikes**

**Specifications - 2 3/8" OD schedule 40 steel**

Model #	# Bikes	Type of mount	weight	length	width	height	Space Requirement
2140	10	Freestand	244 lbs.	154"	18.4"	37"	80" x 240"
2142	10	Freestand	255 lbs.	154"	18.4"	37"	80" x 240"

**To Specify**

**Bicilinea:** Bike racks available in 10' and 20' lengths. 10' accommodates 8 bicycles, and 20' holds 16 bicycles. Stainless steel horizontal tube connects to support posts and curved tubes. Bicilinea must be embedded, and needs some assembly.

### Traditional

### Contemporary

**Landscape Forms Bicilinea bicycle rack**



Saris Bike Corral; place in an on-street parking spot to park 10 bikes



Landscape Forms Bicilinea bicycle rack

# Curb Extensions

Curb extensions extend the sidewalk into the parking lane, thereby calming traffic by visually and physically narrowing the roadway, and reducing the distance a pedestrian has to cross the street. Curb extensions are also a great public amenity, as they create more space for landscaping and streetscape features, and they provide a place to experience or build a community identity.

Because it can take time and money to install a new curb line, there are many creative solutions for temporary curb extensions. These can be removed daily, or seasonally in winter.

Normally, curb extensions are found at the end of a block, utilizing space too small for an additional parking space. They can also be extended to occupy 1-2 parking spaces. The width of a curb extension is typically the parking lane width (seven to eight feet for parallel parking, 16-18 feet for diagonal parking). As shown here, curb extensions also exist mid-block for outdoor seating or community amenities.

## Temporary Curb Extension



Flower planters create a removable curb extension

Mulch is used to designate a temporary extension for cafe seating  
(Photo courtesy of: <http://parkingday.org/frequently-asked-questions/>)

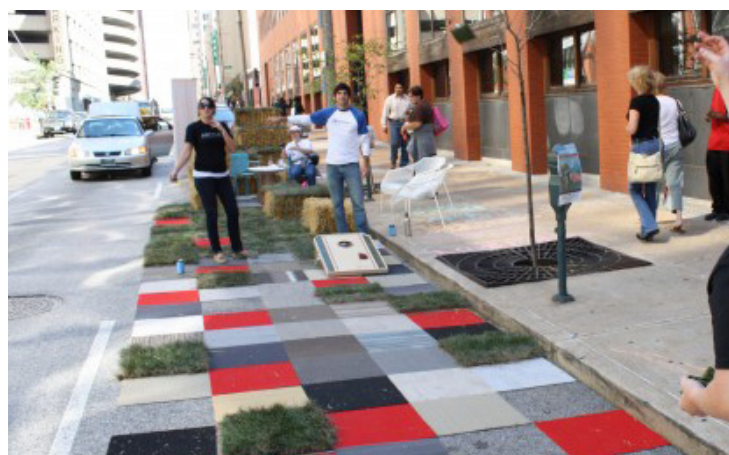

Carpet squares, haybales, and sod create a parklet for National Parking Day  
(Photo courtesy of: [http://blogs.riverfronttimes.com/dailyrft/2011/09/parking\\_day\\_st\\_louis\\_olive.php](http://blogs.riverfronttimes.com/dailyrft/2011/09/parking_day_st_louis_olive.php))

## Installed Curb Extension (Short Term)



Flower planters create a removable curb extension



A seasonal parklet is created over diagonal parking  
(Photo courtesy of: San Francisco Planning Dept., <http://www.flickr.com/photos/sfplanning/8457445876/>)



Installed platform provides cafe seating  
(Photo courtesy of: San Francisco Planning Dept., <http://www.flickr.com/photos/sfplanning/8456346165/>)



Short term curb extension becomes a neighborhood meeting place  
(Photo courtesy of: San Francisco Planning Dept., <http://www.flickr.com/photos/sfplanning/8490264686/>)



Decorative planters with lattice create an outdoor room  
(Photo courtesy of: David Sawyer, <http://www.flickr.com/photos/18702768@N04/2166595909/>)

## Permanent Curb Extension (Long Term)

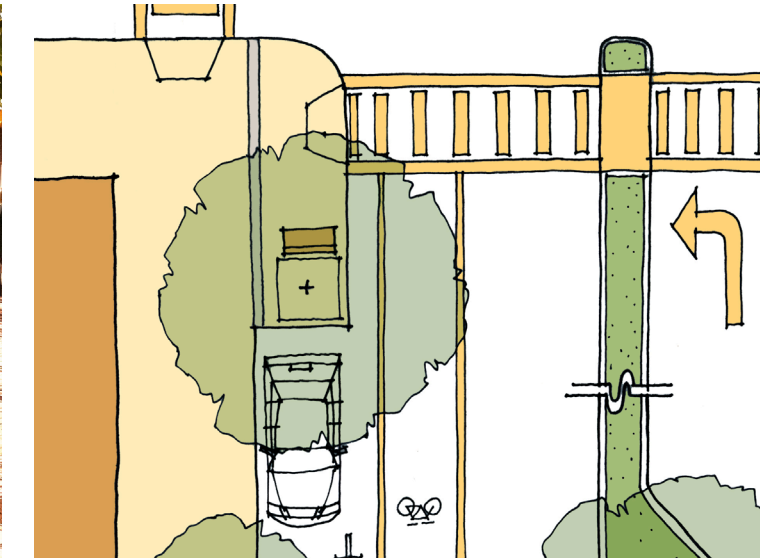

A curb extension allows for street trees and pedestrian safety



A permanent curb extension



This curb extension allows water to drain to the sewer inlet, following the existing drainage line.

# Signage and Wayfinding

## Sign Concepts

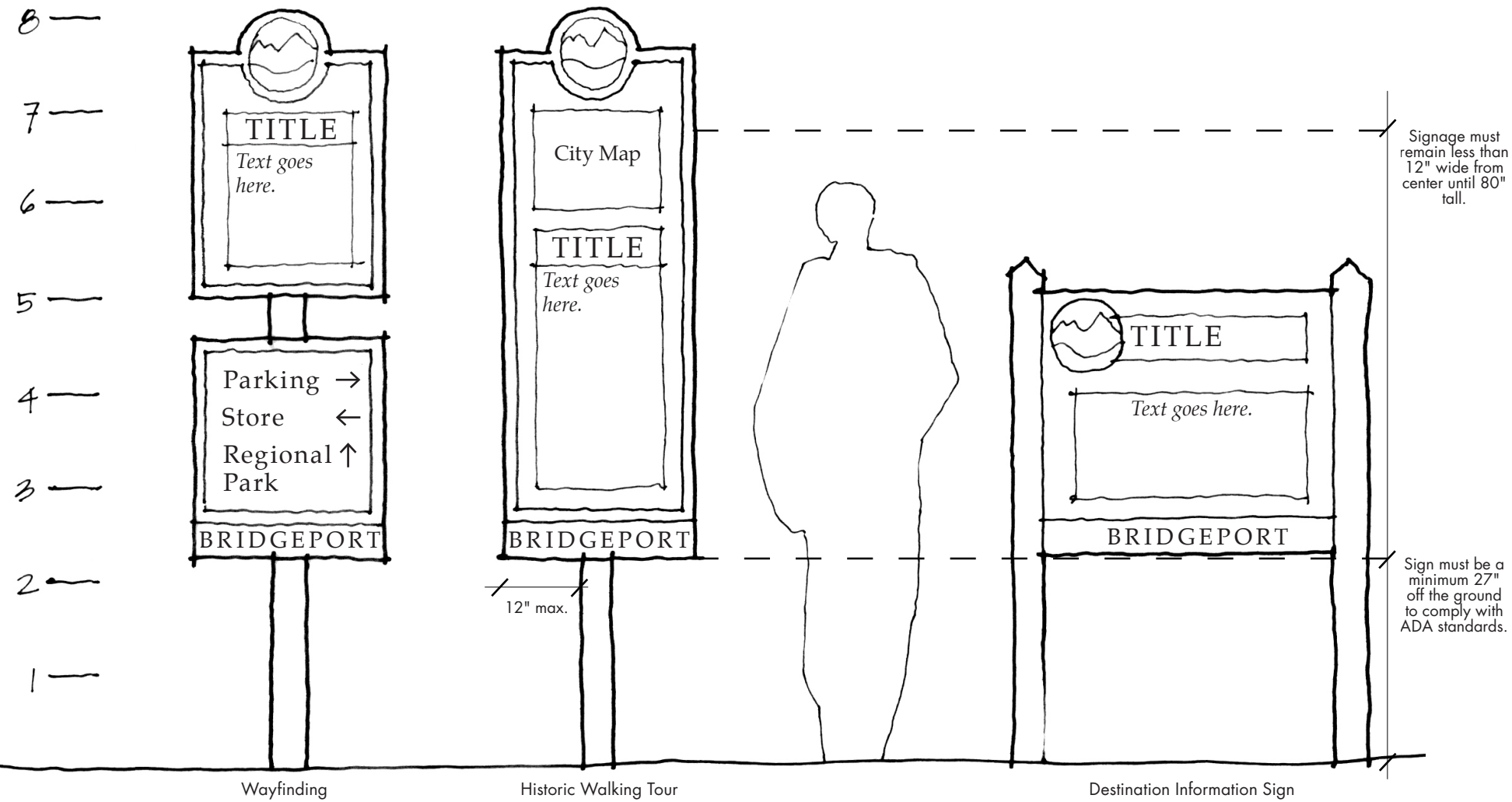

## Banner and Street Sign Placement

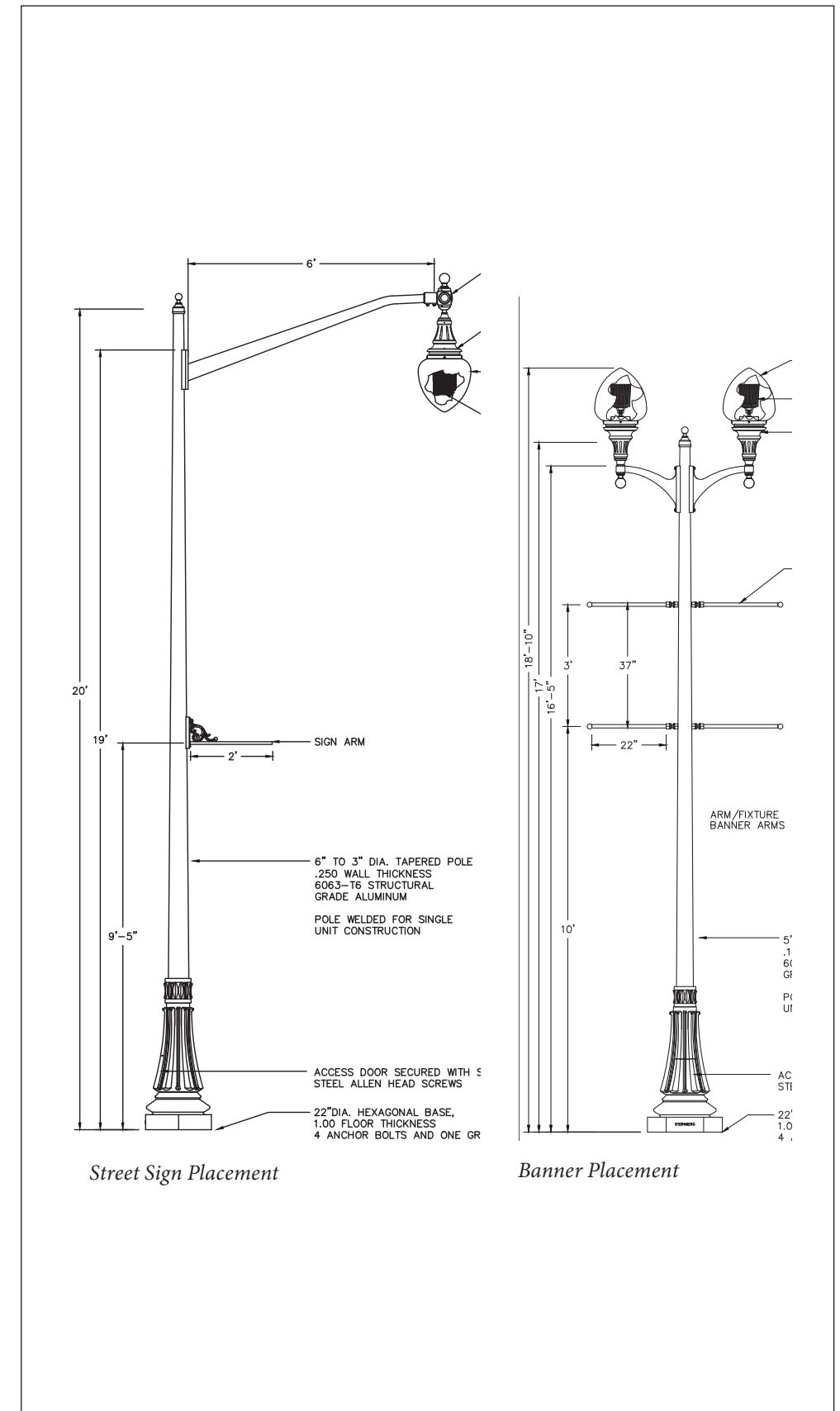

## Color and Font Concepts

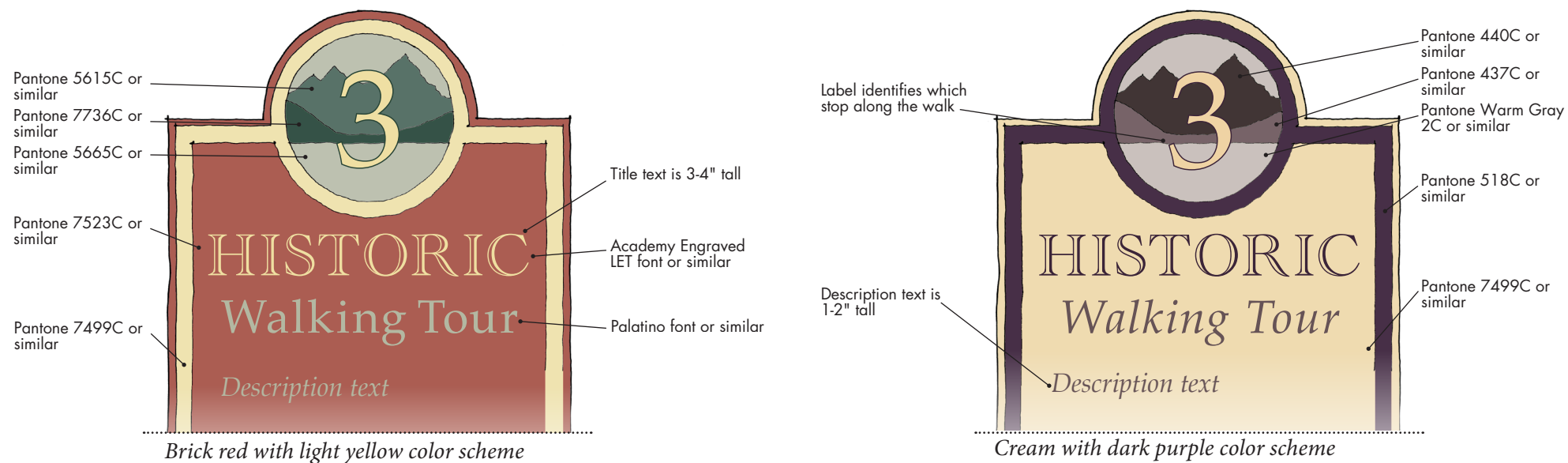



# Gateway Signage

## West Gateway



Gateway location at the intersection of Highway 395 and Emigrant Street

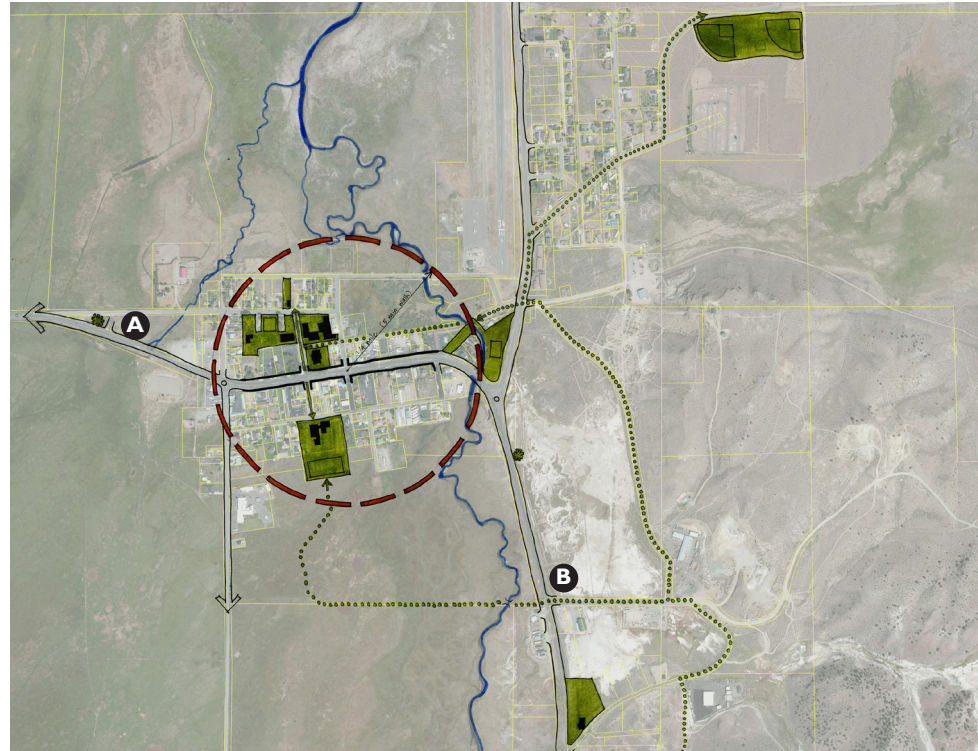

Gateway location plan

## East Gateway



Gateway location south of town, on Highway 395



A conceptual elevation of a gateway element to sit at the western edge of town.

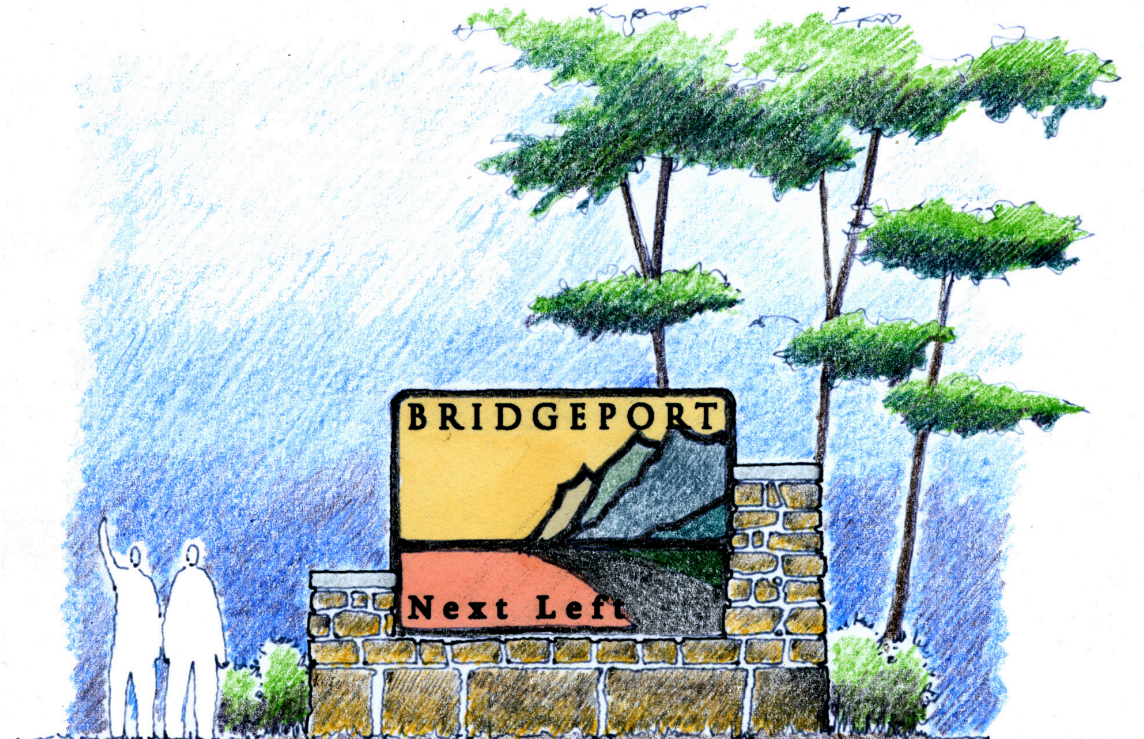

A conceptual elevation of a sign welcoming visitors to Bridgeport from the east.

# East Walker River Bridge: Study 1

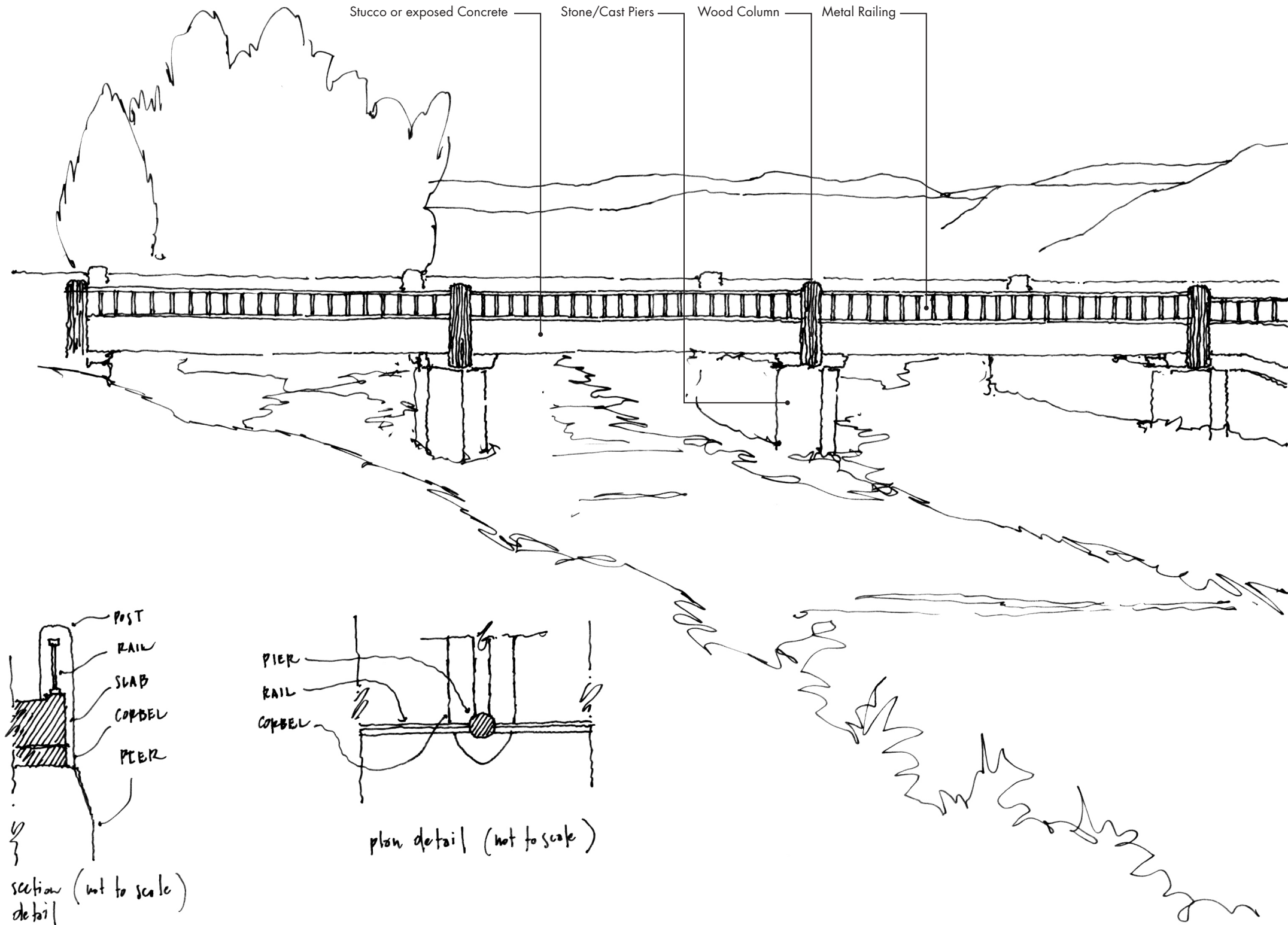

*Yellowstone National Park*

Source: Park & Recreation Structures, Princeton Architectural Press, 1999

# East Walker River Bridge: Study 2

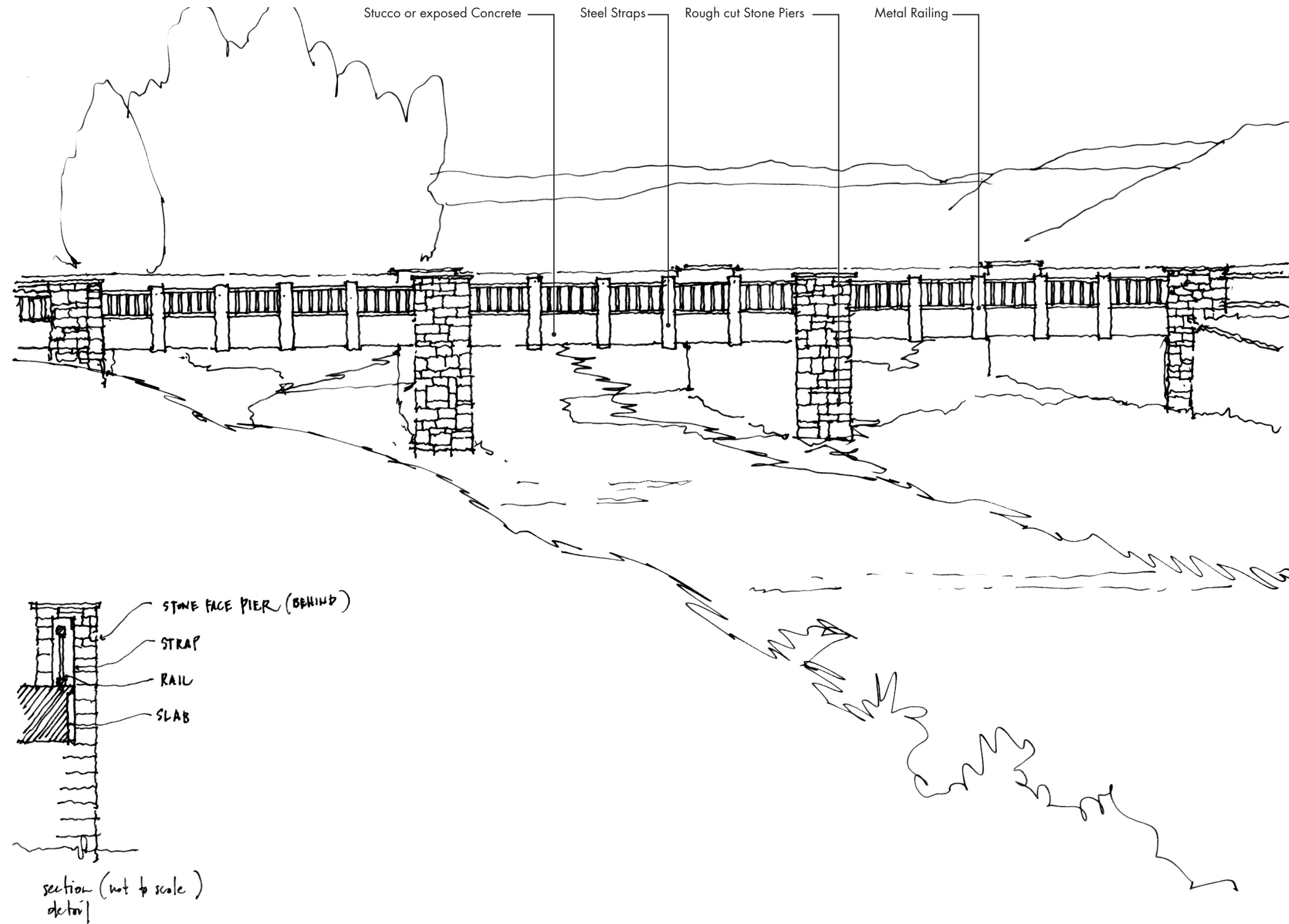

Devil's Den State Park, Arkansas  
Source: Park & Recreation Structures, Princeton Architectural Press, 1999